

Note: This detail was developed to meet the requirements of a specific set of design parameters in a cold/wet climate. Variables such as insulation levels, regional building requirements and contractor preferences may render this detail not applicable to all conditions or situations.

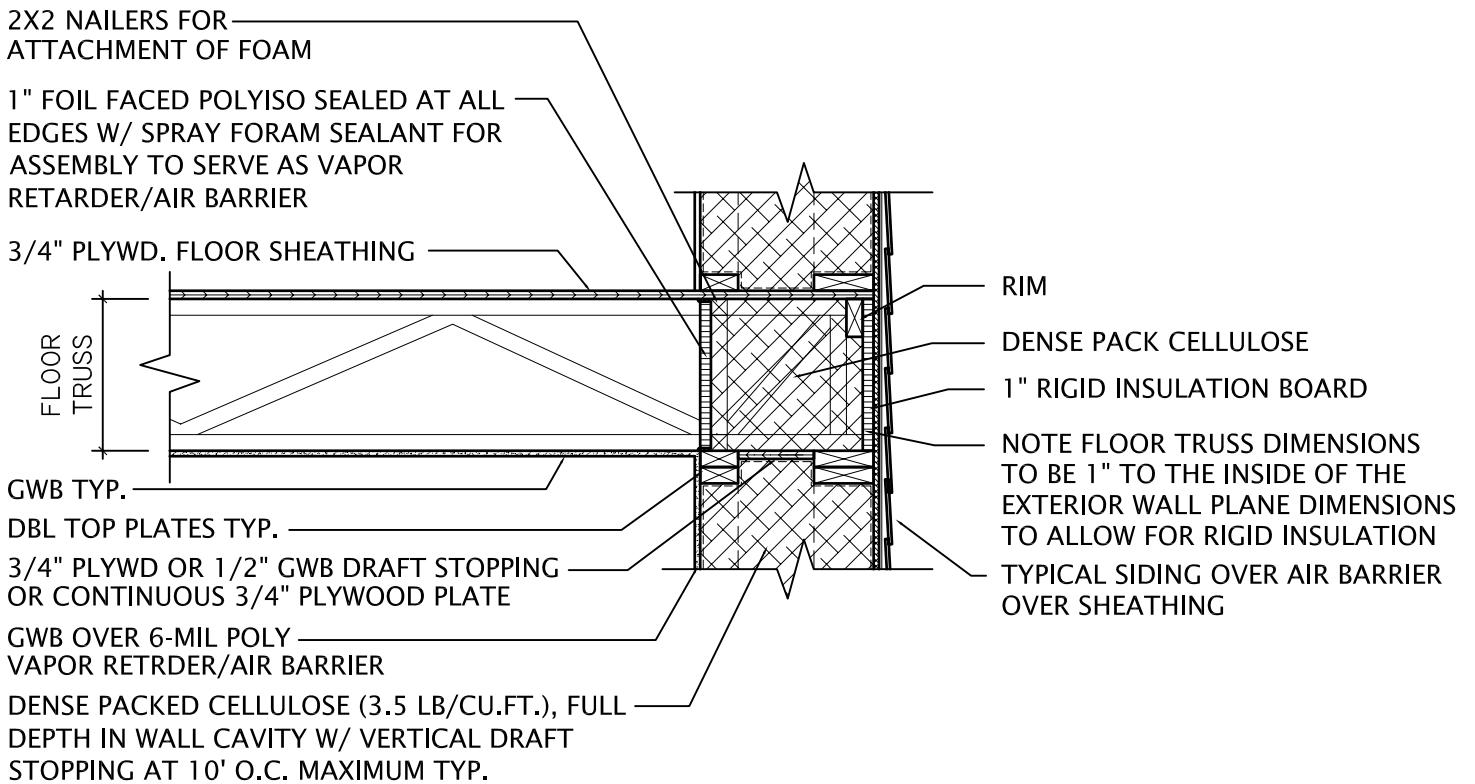

## Double Stud Wall: Floor Truss Connection

